

# > PRIVA BLUE ID S-LINE DOS8

## Solid state output module



An Priva Blue ID S-Line DOS8 Solid state output module provides the system with digital outputs with feedback. The outputs are short-circuit proof and self-restoring in order to increase operational reliability.

### Characteristics

- based on FET technology
- can switch direct current and alternating current
- outputs electrically isolated from system neutral
- each wire has its own terminal block
- field power (FP) loop through
- field ground (FG) loop through
- hot swappable
- 24 V system power supply monitoring
- protection against overload and short-circuits
- LED per output, colour is adjustable
- LED for status of module
- Priva Blue ID Lifeline
- text card for identification of outputs

### Direct current and alternating current

The module can switch both direct current and alternating current. The status of the outputs is fed back by software.

### Short circuit proof and self-restoring

The module's outputs are self-restoring after a brief short-circuit or overload.

If a brief short-circuit or overload occurs, the output is switched on again after half a second. This avoids the need to restart the output manually. After a longer short-circuit or overload, you must first remove the cause of the problem, after which you can restart the output manually.

### Modular design

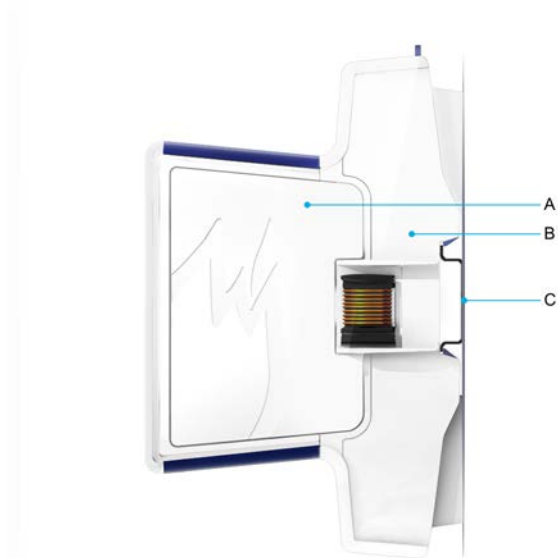

Module (A) and base (B) form a unique combination. As a result of this, a module cannot be incorrectly positioned in a base.

You simply click the base onto the DIN rail (C). The wiring easily connects to the base via spring terminals. The base remains in place when replacing the module, removing the need to rewire.

### Hot swappable

Removing a module from the base and replacing it can easily be done without tools. This can be done live (hot swappable). The outputs switch themselves off when the module is removed.

### Wiring

You do not need to disconnect wiring when exchanging modules. This is because the wiring is connected to the module's base.

## Quick and faultless wiring

Each output has three terminals. In addition to the terminal for the device each output has an FG terminal and an FP terminal that can be used to wire an actuator directly to the module. This avoids the need for additional terminals to loop the wiring through.

## Clear indication

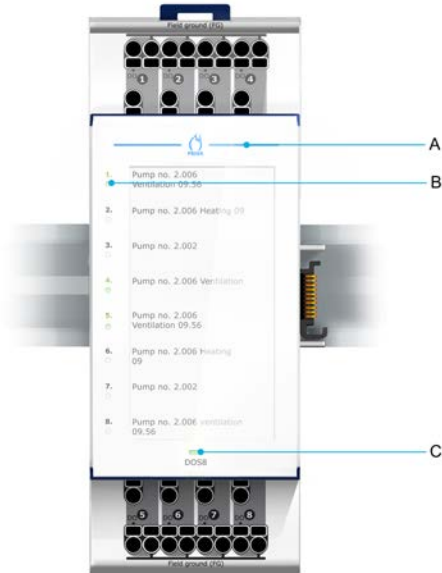

## Legend

A	Priva Blue ID Lifeline
B	LEDs for status of outputs
C	LED for status of module

### Priva Blue ID Lifeline

The modules are equipped with blue LEDs. Together, these LEDs form the Priva Blue ID Lifeline. If the blue line is continuously on, the modules and bases are in the correct place according to the configuration in TC Engineer.

### LEDs for status of outputs

Per output, an LED clearly indicates the status of the output. Depending on the configuration, the LED is green, red or off.

### LED for status of module

The LED shows the status of the module. The LED is on continuously when the module is working correctly. If not, and in special circumstances, the LED flashes.

## Connections

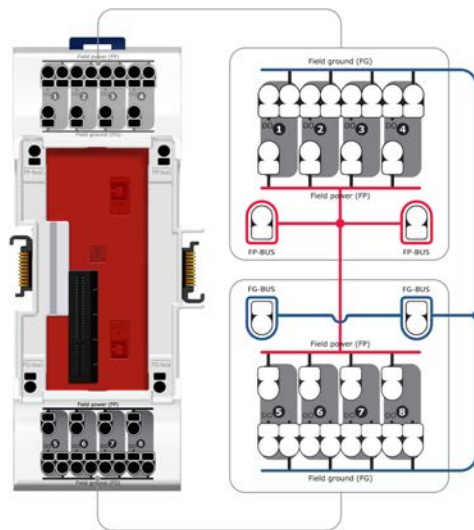

## Legend

DO	digital output
Field power (FP)	power supply for actuators (DC voltage or AC voltage)
Field ground (FG)	output neutral

## DOS8 module specifications

General	
Module article description	Priva Blue ID S-Line DOS8 Solid state output module
Module article number	5071013 (V03:01 and higher)
Base article description	Priva Blue ID S-Line DOS8 Solid state output base
Base article number	5071113 (V02:00 and higher)
Number of outputs	8
Dimensions (XYZ) <sup>1</sup>	161.5 x 61 x 100.2 mm (6.36 x 2.40 x 3.94 inches)
Weight	module: 160 grams base: 160 grams
Maximum power consumption	2.9 W
Typical power dissipation <sup>2</sup>	2.3 W
MTBF <sup>3</sup>	module: 790,000 hours base: 8,760,000 hours
Construction	removable module on a base
Mounting of base	clicks onto DIN rail
Material	mixture of polycarbonate and ABS
Connector type for power supply and I/O	terminal block
Permitted core cross section area	solid: 0.2 ... 4 mm <sup>2</sup> flexible: ... 2.5 mm <sup>2</sup> flexible with ferrule connector: 0.25 ... 1.5 mm <sup>2</sup>
Identification of connections	labelling with an explanatory abbreviation

<sup>1</sup> Excluding 1.1 mm room between the modules

<sup>2</sup> Dissipation under the following conditions:

- I/O load of 50%
- Energy saving mode on (LEDs off)

<sup>3</sup> The MTBF is calculated according to the *Telcordia SR-332 standard Issue 2* under the following conditions:

- ambient temperature: 35 ... 50 °C
- supply voltage: 24 VDC
- time in operation per day: 24 hours
- reliability level: 60 %



Digital solid-state outputs	
Switching voltage	0 ... 30 VAC -30 ... 30 VDC
Output voltage unloaded	output inactive: 0.1 x switching voltage output active: switching voltage
Load current	AC: 0 ... 1.2 A (RMS) DC: 0 ... 1.2 A (continuous)
Maximum load to be connected per module (sum of currents through all outputs)	6 A
Output resistance	< 0,3 Ω
Maximum peak current detection	> 4 A, output switches off immediately
Over-current protection	from 1.2 A (output switches off immediately if RMS current is higher than the specified value for longer than 40 ms)
Protection	output is short-circuit proof (self-restoring) output is protected against overload (self-restoring)
Number of switch-on attempts in the event of short circuit or overload <sup>1</sup>	5
Switch type	FET
Maximum switching frequency	10 Hz at 50 % duty cycle
Maximum connectible self induction	200 mH
Functional isolation of outputs in relation to system neutral	240 VDC 240 VAC
FG isolated from system neutral	yes (via 1MΩ parallel to 10 nF)
Input voltage between FP bus and FG bus	0 ... 30 VAC 0 ... 30 VDC
Field power supply	double isolation between input and output
Maximum FP bus and FG bus current	10 A
Signalling	<ul style="list-style-type: none"> <li>• Priva Blue ID Lifeline</li> <li>• green-red LEDs for status of outputs (colour is adjustable)</li> <li>• green LED for status of module</li> </ul>





<sup>1</sup> After a short-circuit or overload the output is switched back on after 0.5 s. The output switches back off immediately if the overload is still present. The output performs a maximum of 5 switch-on attempts with a time interval of 0.5 seconds. After 5 attempts, the output is switched off and manual intervention is required.

## General specifications of controllers, modules and bases

Housing	
IP code	IP30 (IEC 60529)
Flammability class	V-0 (UL 94)
Recycle code	7
Colour	release surfaces of module and DIN rail release: blue (RAL5013) other parts: white (RAL9003)
Device type	open device, for use in a pollution degree 2 environment

Installation and connection	
Installation	<p>in control panel:</p> <ul style="list-style-type: none"> <li>• accessible to authorized personnel only</li> <li>• can be clicked onto the DIN rail that is positioned horizontally or vertically on the mounting plate</li> </ul> <p>Note: The controller, SC module and SN module may only be mounted horizontally.</p> <p>in panel door integration in control panel:</p> <ul style="list-style-type: none"> <li>• accessible to authorized personnel only</li> <li>• can be clicked onto the DIN rail that is positioned horizontally on the mounting plate</li> </ul>
DIN-rail type	35 x 7.5 mm (height x depth), in accordance with IEC 60715
Maximum width of I/O modules, bus extension modules and controller	20 mm

Environment	
Permitted temperature inside control cabinet during normal operation with horizontally mounted modules only (without airflow)	0 ... 50 °C
Permitted temperature inside control cabinet during normal operation with vertically mounted modules only (without airflow)	0 ... 35 °C
Permitted temperature during transport and storage	-20 ... 70 °C
Permitted relative ambient humidity	10 % ... 95 % (non-condensing)
Shock and vibration resistance	IEC 61131-2
Installation category	II

Legislation and standards	
Canada / USA	 <ul style="list-style-type: none"> <li>• UL 508:2005 (industrial control equipment)</li> <li>• UL 916:2007 (energy management equipment)</li> <li>• UL 61010-1:2004 (measurement and control equipment)</li> <li>• CSA C22.2 No 14-10: 2011 (industrial control equipment)</li> <li>• CSA C22.2 No 205-12: 2012 (signal equipment)</li> <li>• CSA C22.2 No 61010-1-04 (measurement and control equipment)</li> </ul>
	EMC <ul style="list-style-type: none"> <li>• complies with 47 CFR Part 15 Subpart B, Class B (FCC Rules) Operation is subject to the following two conditions:               <ol style="list-style-type: none"> <li>1. This system may not cause harmful interference.</li> <li>2. This system must accept any interference received, including interference that may cause undesired operation.</li> </ol> </li> <li>• ISM-system, complies with Canadian ICES-001</li> </ul>
Europe	 <ul style="list-style-type: none"> <li>• Low voltage directive 2006/95/CE:               <ul style="list-style-type: none"> <li>• EN 61010-1:2010 (measurement and control equipment)</li> </ul> </li> <li>• EMC directive 2004/108/EC:               <ul style="list-style-type: none"> <li>• EN 61326-1:2006 (measurement and control equipment)</li> <li>• EN 61000-6-2:2005 (generic immunity standard)</li> <li>• EN 61000-6-3:2007 (generic emission standard)</li> </ul> </li> <li>• RoHS directive 2011/65/EU</li> </ul>
	 <p>complies with the WEEE directive 2002/96/EC</p>
International	 <ul style="list-style-type: none"> <li>• The Priva Blue ID S10 Controller is BTL registered at BACnet International.</li> <li>• The Priva Blue ID S10 Controller is BACnet certified in accordance with ISO 16484-5/6.</li> <li>• Priva is a member of the BACnet Interest Group Europe.</li> </ul>

Europe Office:  
Priva  
Zijlweg 3  
P.O. Box 18  
2678 ZG  
De Lier  
The Netherlands  
[www.priva.com](http://www.priva.com)  
[sales.building@priva.nl](mailto:sales.building@priva.nl)

UK Office:  
Priva UK Ltd.  
34 Clarendon Road  
  
Watford WD17 1JJ  
United Kingdom  
[www.priva.co.uk](http://www.priva.co.uk)  
[sales@priva.co.uk](mailto:sales@priva.co.uk)

Canada Office:  
Priva North America Inc.  
3468 South Service Road  
Vineland Station  
  
Ontario LOR 2E0  
Canada  
[www.priva.ca](http://www.priva.ca)  
[contact.priva@priva.ca](mailto:contact.priva@priva.ca)

Your Priva partner:

